

Attendance Management System

Shailendra¹, Manjot Singh², Md. Alam Khan³, Vikram Singh⁴, Avinash Patil⁵, Sushma Wadar⁶

^{1, 2, 3, 4, 5, 6}Electronics and Telecommunication Engineering Department,

^{1, 2, 3, 4, 5, 6} Army Institute of Technology,

Pune, India

¹vermashailendra403@gmail.com

²manjotsingh0074@gmail.com

³alamk6796@gmail.com

⁴vikramjadon921995@gmail.com

⁵apatil@aitpune.edu.in

⁶swadar@aitpune.edu.in

Abstract—In today's era regardless of the field of study or preference for defining data (quantitative, qualitative), accurate data collection is essential for maintaining the integrity of research. Selection of appropriate method and the device used for data acquisition reduces chances of errors occurring. Proposed system has a small handy hardware, a remote server and software components for acquisition of data manually or from sensors electronically. It could be used in doing survey's, closed loop control monitoring systems in industries, hospitals, attendance management system of schools and colleges etc. This paper presents a design and framework for taking attendance in schools and colleges, for making troublesome process of taking and compiling of attendance simple and efficient. As its targeted users are educational institutes where there is a requirement of affordable, user friendly, portable, energy efficient and secure automated system. Hence this prototype provides an amalgamated solution for replacing existing conventional attendance system with embedded attendance system. Main advantages are its very low cost, small size, efficient with low energy consumption.

Keywords— data acquisition, attendance management system, raspberry pi web server.

I. Introduction

Attendance is for keeping records of number of students present in schools, colleges or in any organization. It is very important strand in maintaining discipline among employees in an organization and imparting quality education in schools, colleges and if someone drifts from required standards proper action can be taken. Now next important thing is how to take attendance. Conventional way of taking attendance in schools is by calling of names by teacher, students responding on their roll numbers and putting 'A' or 'P' on log book accordingly. Other methods of taking attendance are RFID cards, biometric identifiers like fingerprint [1], face recognition, palm print, hand geometry, iris recognition etc. But conventional method looks better as it is cheaper and more reliable as observer is human being itself. Biggest problem in using conventional method of taking attendance is its tedious, cumbersome process of using this hand written data and then calculating percentage of attendance, sorting, transferring it onto

computer for further website backup. Complexity of this process increases even more with increase in number of students.

Looking for a solution for above mentioned problems in attendance management system of school and colleges this paper presents a prototype which is having advantages of not only the conventional technique of taking attendance but also of latest devices mentioned before that are available nowadays along with universal compatibility.

In proposed system two hardware devices are there, first one is a handheld device which will be there in every classroom for taking attendance and second one will be a local server for all handheld devices in the network. Handheld devices are designed on ATMEGA16 microcontroller interfaced with Real Time Clock (RTC), Electrically Erasable Programmable Read Only Memory (EEPROM), 4x3 keypad, 16x2 Liquid Crystal Display (LCD), ZigBee module. Local server is Raspberry Pi web server which is based on ARM1176JZF-S processor interfaced with ZigBee series 2 module based on an IEEE 802.15 standard.

This paper is organized as follows: Section II consists of Hardware Components, Section III deals with Software Components and Section IV consist of concluding remarks.

II. Hardware Components

Basically hardware in attendance management system consists of two sub-systems:-

1. Handheld devices employed for taking and sending attendance.
2. A local server with ZigBee for monitoring all the devices in its network and updating website with daily attendance records [2].

A. Handheld Device

Handheld device is a key unit in this system. As attendance is to be taken by this device so its components should fulfill requirements of the system like low cost, low power, high processing speed. For this AVR ATMEGA16 of ATMEL a

low power CMOS 8 bit microcontroller was selected which is an on chip Reduced Instruction Set Computing (RISC) core having modified Harvard Architecture [3]-[5]. Storing of attendance record in EEPROM is also very important part of this system. For storage AT24c64 EEPROM of ATMEL which provides 65536 bits of serial electrical erasable and programmable read only memory organized as 8192 words of 8 bit each could be selected [6]. This much of memory could store attendance for one semester with four lectures on each day. For data transfer between ATMEGA16 and AT24c64 Inter-Integrated Circuit (I2C) protocol is being used. I2C bus physically consists of two active wires and a grounded connection using SDA (serial data line) and SCL (serial clock line) which are both bi-directional. Refer software section for detailed working of I2C protocol. Attendance record has to be stored in EEPROM in accordance with date and time given by Real Time Clock (RTC) DS1307 of MAXIM INTEGRATED. This is used on the same I2C bus [7]. To provide user interface Liquid Crystal Display (LCD)-016M002B of VISHAY was connected [8]. For transmitting data from the handheld devices network to local Raspberry Pi web server wirelessly XBee XB24-Z7WIT-004 from DIGI was used [9], [10]. The main

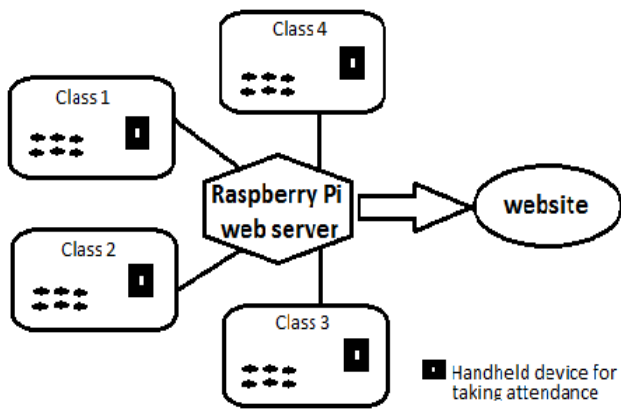

Figure 1. System Architecture

benefits of using ZigBee XBee was its third-party device support and low power requirements.

Handheld device is working on 5V DC. So an adapter (12V, 1Amp) and IC7805 was used as voltage regulator for power supply. A 9V battery could also serve all its power requirements.

The main purpose of this device is to take and send attendance records on a daily basis to the local server. So for taking attendance a keypad is provided through which after authorization teacher enters the attendance which simultaneously gets stored in EEPROM in accordance with subject, date and time. This stored data can then be send to its local server either via ZigBee wirelessly in the form of data packets or through wires using RS232 serial device provided on device to the computer directly through a single USB port.

For overall functioning, the device is having various modules/functions [11]. These are as follows:-

- Attendance function
- Date and time function
- Power management function
- Reboot function
- Display function
- Security function

These functions are discussed in section III.

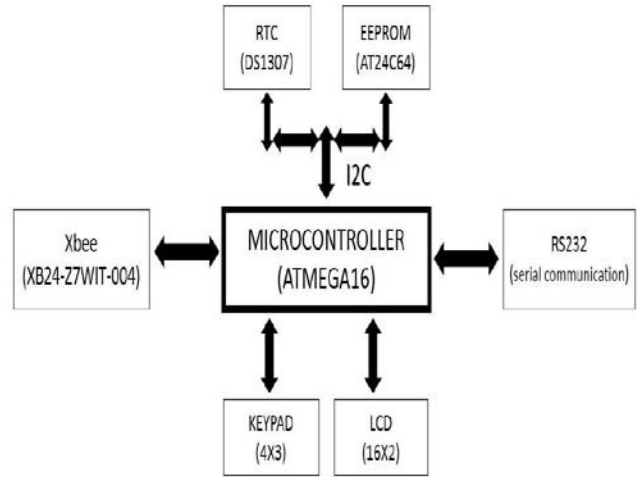

Figure 2. Block Diagram of Handheld Device.

B. Raspberry Pi Web Server

Attendance records sent by handheld devices are received by a local server. Raspberry Pi as sever was chosen because it draws extremely low power, small form factor, no noise, solid state storage. Raspberry Pi model B [6], [8].

Developed by RASPBERRY PI based on ARM1176JZF-S, 700 MHz processor, is present as a local web server. For Raspberry Pi hardware DEBIAN optimized operating system RASPBIAN is used. For long and effective wireless transmission ZigBee series 2 module was interfaced with it. It provides extensive hardware support for packet handling, data buffering, burst transmission, clear channel assessment, link quality and indication.

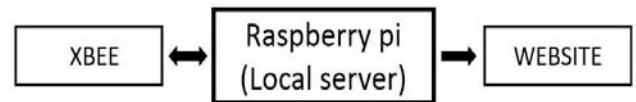

Figure.4. Block Diagram of Raspberry Pi Local Web Server

Main purpose of the server is to receive serial data from handheld devices, make an excel spreadsheet (.xml) file containing attendance records using Python interface [12], [13]. Now server updates its website with these attendance sheets. Refer software section so as how the Raspberry Pi is made a local server.

An impediment to the above system can be its limited range, as range has to be observed closely while implementing

the system. However this could be avoided by successful field observation before the system is implemented. As the device is working on a 9V battery which needs to be changed

In this application, Xbee connected to the PC as a coordinator, and the remote Xbee as an end device. This

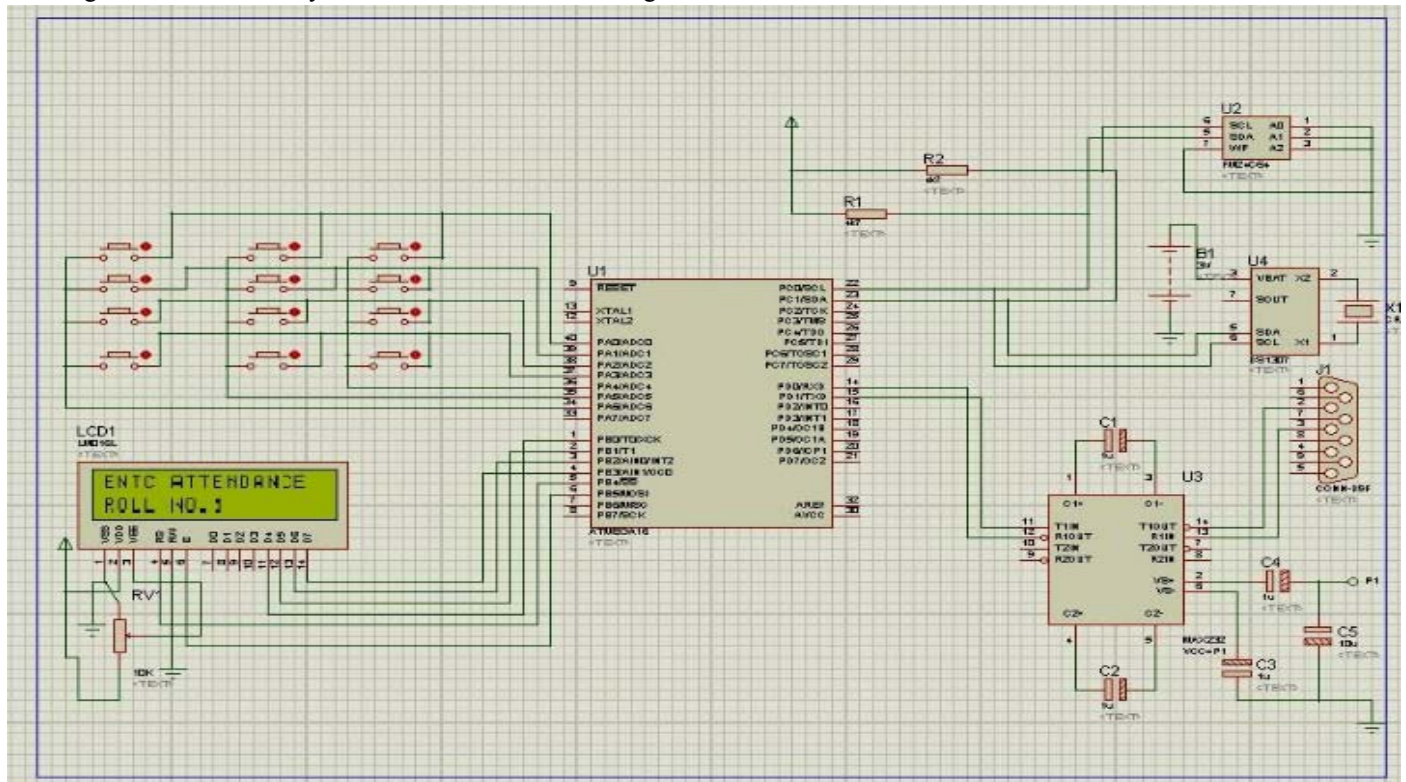

periodically.

Figure 3. Hardware Design of Handheld Device on Proteus Simulation

III. Software Components

Inter integrated Circuit Protocol (I2C) was used for connecting on chip peripherals. I2C is a two-wire serial bus called SDA and SCL, are both bi-directional. SDA is the Serial Data line, and SCL is the Serial Clock line which operates on 400kbps. EEPROM an RTC are interfaced using I2C protocol. 7 bit device addressing mode and 9bit data addressing are used. Connected devices has its own unique address and it can act as a receiver/transmitter. Microcontroller issues a START condition and then it sends the address of the device it wants to access. Once the address is matched the acknowledge bit is received and the communication starts between the devices.

Zigbee is a low-power, short range wireless devices based on an IEEE 802 standard for personal area networks (PAN). ZigBee modules work in unlicensed ISM (Industrial Scientific Medical) band. ZigBee devices are capable of peer-to-peer, point-to-multipoint and mesh communication. They offer convenient low power wireless solutions for embedded systems where power consumption is a critical factor. A ZigBee network consist of three different types of ZigBee devices: coordinator, router, and end-device. Each network has a 16bitPAN ID [1], [2].

allowed to use the Xbee connected to the PC to send commands to a remote Xbee, and also to set up automatic I/O sampling on the remote Xbee.

X-CTU is XBee Configuration and Test Utility. It is primarily used for configuring XBee Modules from DIGI and

also to upgrade the on board microcontroller firmware. It comes with a Serial-Terminal to interact with XBee modem using AT commands.

The software part in the system is again divided in two subparts:-

1. Handheld device software – functioning of modules and software’s used.
2. Local server software – making Raspberry Pi as local web server and software’s used.

A. Handheld Device

Device includes some sophisticated functions (mentioned in section II-A) which takes care of its functionality. Programming of the microcontroller was done using Atmel Studio6 programming software. Attendance function controls attendance related matters such as saving, erasing, loading, and recording. Date and Time function woks simultaneously with real time clock (DS1307) which is active in background implicitly. Power Management function implements two functions namely power save and auto power save function. In power save user could explicitly switch device in power save

mode defined by the controller whereas in auto power save mode it automatically goes in power saving mode if the device is idle for some time. Reboot system provides the user facility to reset the system. Display function helps in interaction of user and the device. Security function keeps the track of the users and allow only authentic users to use the device.

B. Local Server

Attendance system should also have a website backup [14] where all the updates in attendance records could be seen. For this a server is needed which could host the website, and Raspberry pi is used for the same [15]. For configuring Raspberry Pi as web server following steps are performed:-

1. Configure Raspberry pi with Debian image and supporting software's like PUTTY.
2. Allow SSH connections.
3. Change host name.
4. SSH login
5. Change default password.
6. Install Apache with PHP and MySQL.
7. Install a FTP server.
8. Installing phpMYAdmin.

After these steps a 5 Watts economical Raspberry pi server is ready. Connecting ZigBee to it makes it a portable wireless server [15]. This server hosts a website which displays all the attendance records.

The website of "Attendance Management System" is developed to provide a platform to view the attendance. This website could be linked with the institutions website and gets regularly updated from Excel sheet generated by Raspberry Pi Web Server [16]. This website is developed on the server-side scripting language –PHP, the style sheet language –CSS which is used, for look and formatting of a document written in a mark-up language. This website uses MySQL database which is world’s most widely used open source relational database management system (RDBMS). The website also uses JavaScript to create some dynamic elements on the webpages. Full database connectivity is provided through the user interface of the webpages for the admin and the teachers to enter details. The website is divided into four segments (a.)Students (b.)Teachers (c.)Admin (d.)Director/ Head of Department (HOD). Admin will give the IDs and passwords to the members of the institution with minimum required viewing rights. Students will only have the rights to view their attendance. In teachers section teachers can make changes in the attendances if any amendment is required. Director/Head of Department (HOD) will have full accessibility to attendance of each and every student of the institution. In case of any dissatisfaction students have to concern to the teacher directly. The director and HOD’s can keep an eye to the student’s

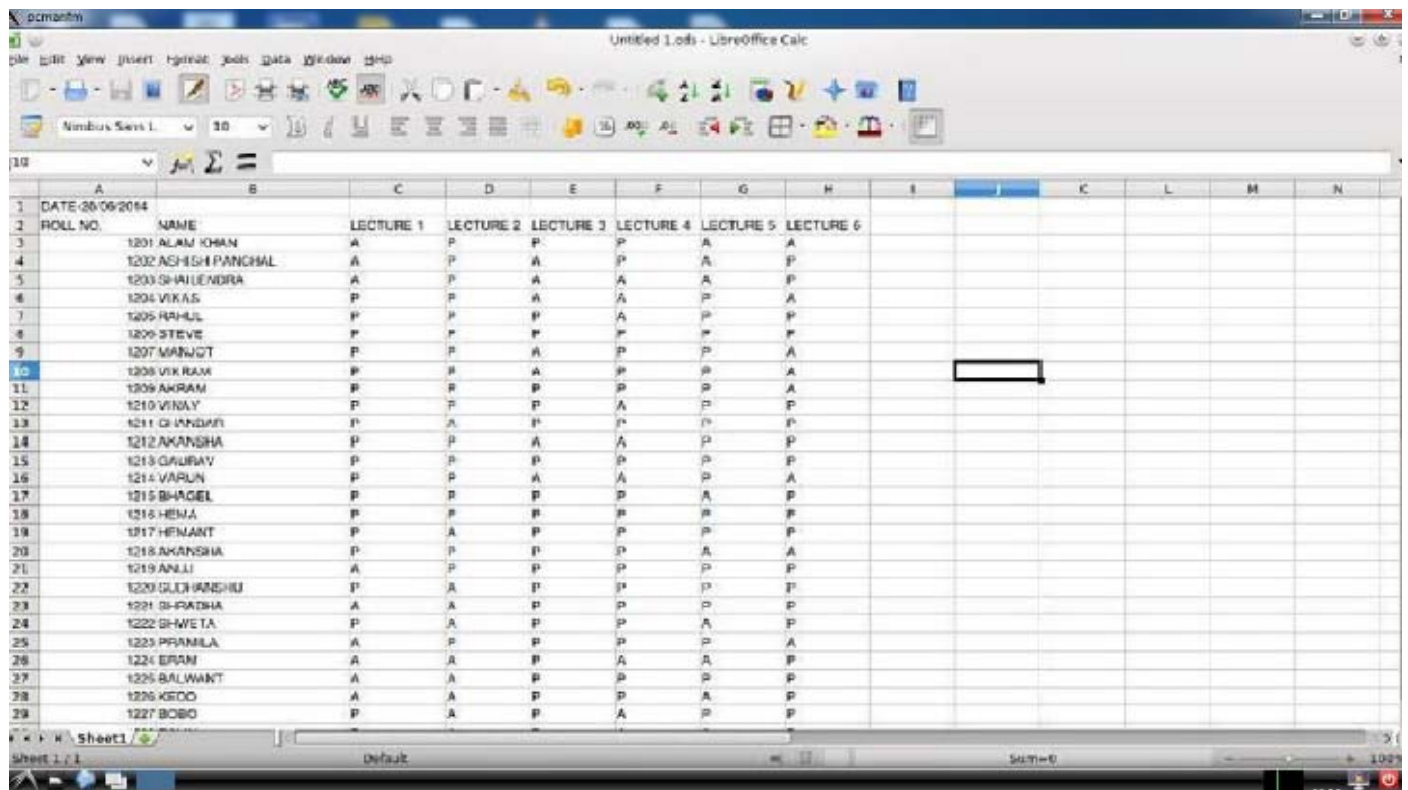

Figure 5. Excel Sheet as generated by Raspberry Pi.

attendance directly so that there is no scope of defaulters.

IV. Conclusion

Based on the requirements of an automated attendance system this servers as a whole system for managing attendances in schools and colleges. It presents a design and framework for taking attendance and thereby making troublesome process of taking and compiling of attendance simple and efficient. So this prototype is not only cheaper, efficient, having low power design, upgraded for any other type of data acquisition system, easy to use but also not having any troublesome process of installation like in biometric and RFID devices which includes wall mounting and stretching of long wires [16].

Acknowledgment

WE ARE HIGHLY THANKFUL TO ARMY INSTITUTE OF TECHNOLOGY, PUNE, INDIA FOR PROVIDING US THE FACILITY TO CARRY OUT OUR PROJECT. WE ARE ALSO THANKFUL TO DR. (PROF.) B.P. PATIL (ELECTRONICS AND TELECOMMUNICATION DEPARTMENT), FOR THEIR CONTINUOUS ENCOURAGEMENT AND SUPPORT.

References

- [1] Li Jian-po; Zhu Xu-ning; Li Xue; Zhang Zhi-ming; Ji-sheng Sui, "Wireless Fingerprint Attendance System Based on ZigBee Technology," Intelligent Systems and Applications (ISA), 2010 2nd International Workshop on , vol., no., pp.1,4, 22-23 May 2010. doi: 10.1109/IWISA.2010.5473360
- [2] Jung, J.Y.; Lee, J.W., "ZigBee Device Access Control and Reliable Data Transmission in ZigBee Based Health Monitoring System," Advanced Communication Technology, 2008. ICACT 2008. 10th International Conference on , vol.1, no., pp.795,797, 17-20 Feb. 2008 doi: 10.1109/ICACT.2008.4493875.
- [3] Dhananjay V.Gadre , "Programming and customizing The AVR Microcontroller ", IEEE transactions on Industry Applications, Vol-40, No-9, May 2005, pp. 356-366.
- [4] Muhammad Ali Mazidi ,Sepehr Naimi,Sarmad Naimi , "The AVR Microcontroller and Embedded System ,using Assembly and C" , pp 629-653.
- [5] Atmel Datasheet. ATmega16 <http://www.atmel.in/Images/doc2466.pdf>.
- [6] Matt Richardson and Shawn Wallace, "Getting Started with Raspberry Pi" ,pp 146-150.
- [7] Chaklader, S.; Alam, J.; Islam, M.; Sabbir, AS., "Bridging Digital Divide: 'Village wireless LAN', a low cost network infrastructure solution for digital communication, information dissemination & education in rural Bangladesh," Advances in Electrical Engineering (ICAEE), 2013 International Conference on , vol., no., pp.277,281, 19-21 Dec. 2013 doi: 10.1109/ICAEE.2013.6750347.
- [8] Matlab The Language of Technical Computing, External Interfaces Version -6 (The Math Works).
- [9] J. Ryyanen, S. Lindfors, K. Stadius, and K. A. I. Halonen, "Integrated circuits for multiband multimode receivers", IEEE Circuits and Systems Magazine, Vol. 6, No. 2, pp. 5-16, 2006.
- [10] K. Chun, J. Lee, J. H. Kim, H. C. Kim, K. J. Yoon, Y. I. Kim, and I. S. Song, "A WLAN/WMAN Dual Mode transceiver System for Indoor/Outdoor Application", 2nd International Symposium on Wireless Pervasive Computing, pp. 156-159, San Juan, Puerto Rico, 2007.
- [11] Zengguang Zhang; Peng Gong; Lijun Cao; Yunlei Chen, "Design and Implementation of Educational Administration Attendance Management System Based on B/S and C/S," Information Technologies and Applications in Education, 2007. ISITAE '07. First IEEE International Symposium on , vol., no., pp.606,609, 23-25 Nov. 2007. doi: 10.1109/ISITAE.2007.4409359
- [12] Simon Monk, "Programming the Raspberry Pi : Getting Started with Python".
- [13] Brian R. Hunt, Ronald I. Lipsman, Jonathan M. Rosenberg, "A Guide To Matlab", pp 121-132.
- [14] Othman, M.; Ismail, S.N.; Noradzan, H., "An adaptation of the web-based system architecture in the development of the online attendance system," Open Systems (ICOS), 2012 IEEE Conference on , vol., no., pp.1,6, 21-24 Oct. 2012. doi: 10.1109/ICOS.2012.6417619
- [15] Pico, F.; Guillo, A; Lopez, J., "Remote Web server of digital signal processors cards and its applications in education," Multimedia Computing and Systems, 1999. IEEE International Conference on , vol.1, no., pp.880,884 vol.1, Jul 1999.
- [16] Moksini, M.I; Yasin, N.M., "The Implementation of Wireless Student Attendance System in an Examination Procedure," Computer Science and Information Technology - Spring Conference, 2009. IACSITSC '09. International Association of , vol., no., pp.174,177, 17-20 April 2009. doi: 10.1109/IACSIT-SC.2009.130